

The Krube logo is located in the top left corner, enclosed in a white circle with a blue border. The logo itself consists of the word "Krube" in a bold, black, sans-serif font, with a small orange and black graphic element to the right of the letter 'e'.

Krube

规格书

SPECIFICATION

MODEL
K-DC17251 SERIES

● General Specifications

- ⌚ Material ----- Frame:Aluminum,Impeller
Impeller:Plastics (Flammability:UL94V-0)
- ⌚ Lead Wire ----- + Red - Black (Sensor) Brown (Control)Yellow
- ⌚ Life time -----50000 Hours Ball bearing
- ⌚ Storage Temperatur--- -30°C ~ +70°C (Non-condensing)
- ⌚ Bearing Type----- Ball Bearings Sleeve
- ⌚ Speed Range----- ±10%



172 X 51mm (Mass:830g)

Model No.	Rated Voltage	Operating Voltage	Rated Current	Rated Input	Speed	Maximum Air Flow		Max.Static Pressure		Noise
	VDC	VDC	AMP	Watt	R.P.M	M3/min	CFM	Pa	IN H2O	dB-A
K-DC17251-HHG-12D	12	8~13.2	1.25	15.0	3700	6.59	232	220	0.883	51
K-DC17251-VHG-12D			1.95	23.4	4400	7.84	276	425	1.707	56
K-DC17251-SHG-12D			2.7	32.4	5000	9.08	320	540	2.17	58
K-DC17251-GHG-12D			3.3	39.6	5500	10.02	353	600	2.41	60
K-DC17251-UHG-12D			5.6	67.2	7000	11.87	418	800	3.21	69
K-DC17251-HHG-24D	24	14.5~27.2	0.625	15.0	3700	6.59	232	220	0.883	51
K-DC17251-VHG-24D			0.975	23.4	4400	7.84	276	425	1.707	56
K-DC17251-SHG-24D			1.35	32.4	5000	9.08	320	540	2.17	58
K-DC17251-GHG-24D			1.65	39.6	5500	10.02	353	600	2.41	60
K-DC17251-UHG-24D			2.8	67.2	7000	11.87	418	800	3.21	69
K-DC17251-XHG-24D			6.33	152	9200	15.48	545	1120	4.49	75
K-DC17251-HHG-48D	48	36.0~55.0	0.32	15.3	3700	6.59	232	220	0.883	51
K-DC17251-VHG-48D			0.49	23.5	4400	7.84	276	425	1.707	56
K-DC17251-SHG-48D			0.68	32.6	5000	9.08	320	540	2.17	58
K-DC17251-GHG-48D			0.83	39.8	5500	10.02	353	600	2.41	60
K-DC17251-UHG-48D			1.4	67.2	7000	11.87	418	800	3.21	69
K-DC17251-XHG-48D			3.16	152	9200	15.48	545	1280	5.15	75

● Dimensions(unit:mm\inch)

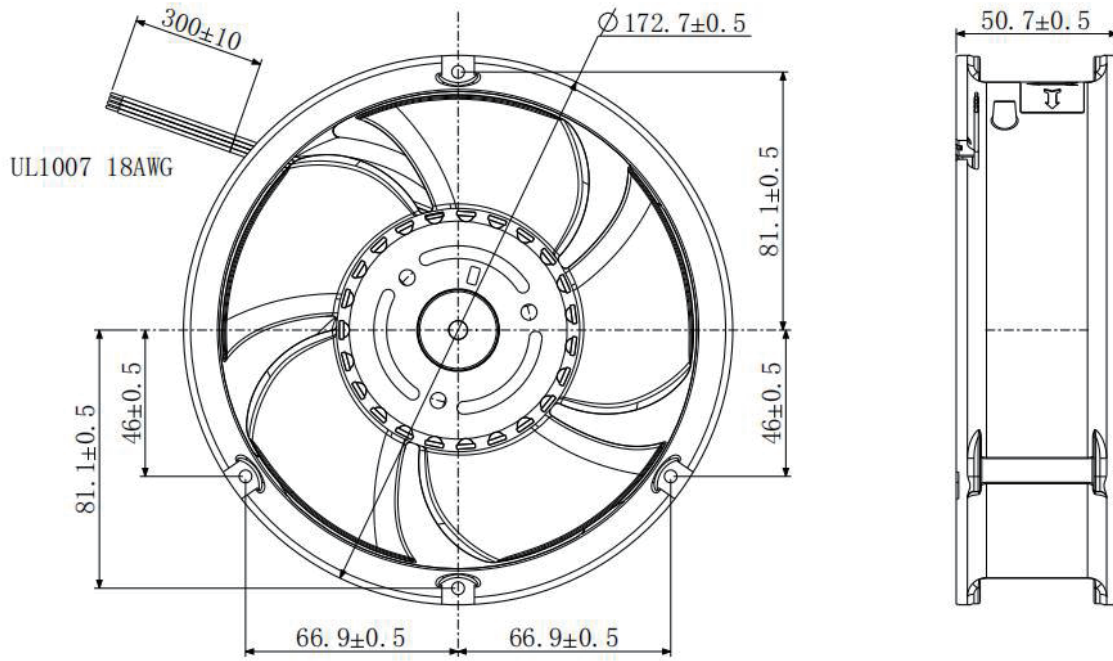

● Air Flow-Static Pressure Characteristics

